

CONTACT CU CORROSION CONTROL
VEHICLE #156/167 WHEN WELDED
STEEL GAS MAIN AND/OR WELDED
STEEL GAS SERVICES ARE EXPOSED.

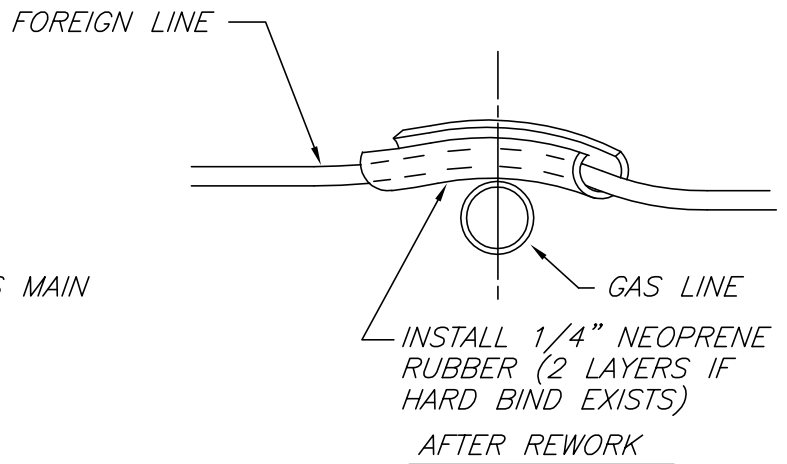

SECTION A-A

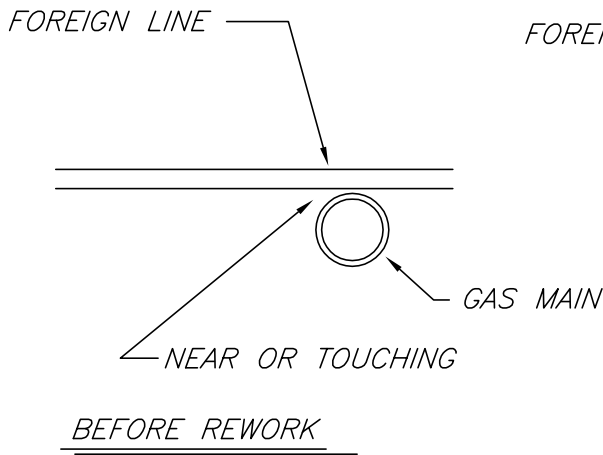

GENERAL NOTES

- PULL FOREIGN LINE FOR AS MUCH SEPARATION AS POSSIBLE. ATTEMPT TO ACHIEVE A MINIMUM 12 INCHES OF SEPARATION.

**CONSTRUCTION STANDARD
CITY UTILITIES
OF SPRINGFIELD, MISSOURI**

**SERVICE LINE
CROSSING REWORK**

LATEST REV. DATE
05/21/97

STANDARD NO.
GS-185

PAGE: